

USER INSTRUCTIONS

- MODULIFT 50

Modulift[®]
working between the hook and the load

The Modulift Spreader is modular in length. Every spreader consists of 1 pair of End Units & Drop Links, with intermediate struts that can be assembled to achieve different spans. The Modulift 50 has an assembled span ranging from 1 metre to 11 metres in 0.5 metre increments.

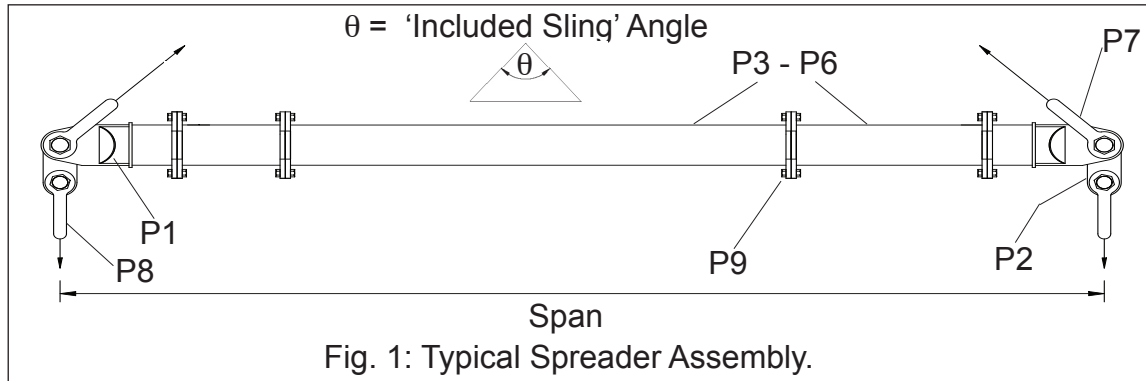
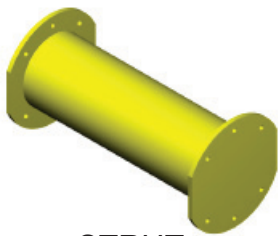

TABLE 1: COMPONENT LIST		
PART REF:	DESCRIPTION	WEIGHT / ITEM
P1	END UNIT	38kg
P2	DROP LINK	11kg
P3	4.0m STRUT	140kg
P4	2.0m STRUT	82kg
P5	1.0m STRUT	53kg
P6	0.5m STRUT	38kg
P7	35t SHACKLE	19kg
P8	25t SHACKLE	14kg
P9	M20x65, GRADE 8.8, HT BOLTS, NUTS & WASHERS	



STRUT



DROP LINK

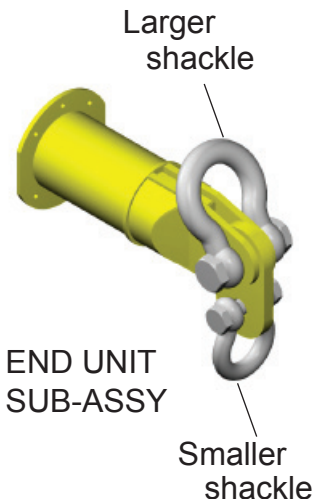

END UNIT SUB-ASSY

Modulift 50 - Beam Specification.

- Rated at 50 tonnes WLL at 6 metres span. See Load Table for WLL at longer spans.
- 'Included Sling' angle θ , 90 degrees or less.
- End Units & Drop Links are rated at 25 tonnes (50 tonnes combined capacity).
- **Bolt tightening torque: 150Nm.** Spanner size required: 30mm.



WARNING!

- Personnel using this system should be suitably trained, competent and have a clear understanding of Safe Slings procedures.
- The use of Modulift equipment must comply with procedures laid down in the Australian Standard: AS 4991 - 2004: Lifting Devices.
- NEVER EXCEED STATED WLL - ADHERE TO WLL IN TABLE 2, FOR PARTICULAR SLING ANGLE USED.
- THE SLING LENGTH IS CRITICAL TO THE SAFE USE OF THE SPREADER - ADHERE TO TABLE 2.
- Ensure Drop Links hang down, and smaller shackles are connected to bottom hole of Drop Link.

USER INSTRUCTIONS

- MODULIFT 50

TABLE 2: Load v Span.

90° ISA			Recommended Configuration. EU - End Unit (0.5m)				60° ISA				
Span / m	WLL / t	Min Sling Length/m	EU	EU	EU	EU	Span / m	WLL / t	Min Sling Length/m		
1	50	0.7	EU	EU			1	50	1.0		
1.5	50	1.1	EU	0.5	EU		1.5	50	1.5		
2	50	1.5	EU	1	EU		2	50	2.0		
2.5	50	1.8	EU	1	0.5	EU	2.5	50	2.5		
3	50	2.2	EU	2	EU		3	50	3.0		
3.5	50	2.5	EU	2	0.5	EU	3.5	50	3.5		
4	50	2.9	EU	2	1	EU	4	50	4.0		
4.5	50	3.2	EU	0.5	2	1	EU	4.5	50	4.5	
5	50	3.6	EU	4	EU		5	50	5.0		
5.5	50	3.9	EU	4	0.5	EU	5.5	50	5.5		
6	50	4.3	EU	4	1	EU	6	50	6.0		
6.5	42	4.6	EU	0.5	4	1	EU	6.5	50	6.5	
7	35	5.0	EU	4	2	EU	7	50	7.0		
7.5	29	5.3	EU	0.5	4	2	EU	7.5	50	7.5	
8	25	5.7	EU	1	4	2	EU	8	43	8.0	
8.5	22	6.0	EU	0.5	1	4	2	EU	8.5	38	8.5
9	19	6.4	EU	4	4	EU	9	33	9.0		
9.5	17	6.8	EU	4	4	0.5	EU	9.5	29	9.5	
10	15	7.1	EU	4	4	1	EU	10	26	10.0	
10.5	13	7.5	EU	1	4	4	0.5	EU	10.5	22	10.5
11	11	7.8	EU	2	4	4	EU	11	19	11.0	

ISA= 'Included Sling' angle, θ

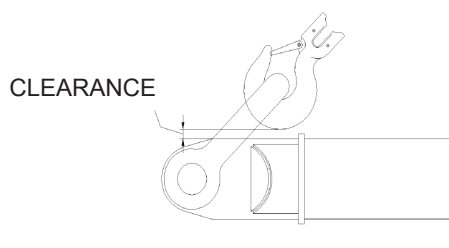
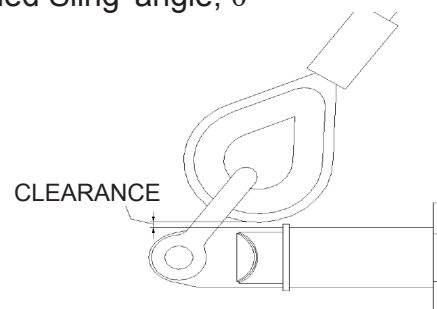

The operator must ensure that there is a clearance between the sling end fitting and the end unit as shown.

- Max number of struts allowed in spreader assembly: 5
- Assemble longer struts in the centre of the spreader configuration
- Sling angle is crucial to safe use of spreader

Recommended top sling types: Textile slings, wire rope slings with soft eyes and chain slings with small end fittings. If thimble eyes are used with wire rope slings, make sure sling angle is 60 degrees or less. Other types exist but not all are suitable due to end fitting size, particularly larger capacity chain hook and thimble eyes. Note: Raising the slings can give greater clearance. Refer to Modulift supplier if in doubt.

ASSEMBLY PROCEDURE.

1. Check the ID plates on each Modulift component to ensure the correct size is used.
2. Lay out the Struts and End Units in the correct configuration (see table 2), laid on flats to prevent rolling.
3. Check that all pairs of flanges are clear from debris, sand etc. before connection.
4. Bolt the components together using bolts, nuts & washers provided. Tighten the bolts to a torque as shown overleaf, 6 bolts per connection.
5. Place drop link inside the jaw of an end unit, with the larger hole of drop link lined up with the End Unit hole.
6. Place a top sling onto the body of a top shackle, and put jaw of top shackle over the end unit jaw.
7. Put top shackle pin through shackle, end unit jaw and drop link, and repeat for other spreader beam end.
8. Attach free ends of top slings to crane hook.
9. Attach lower slings and shackles to lower holes of drop links, and attach them to the load to be lifted.
10. The assembled spreader beam and lifting rig must be thoroughly checked by a competent person prior to lifting.

DO's & DON'TS.

- Do ensure to load the spreader through the drop links only. i.e. adhere to Fig. 1.
- Do ensure enough clearance between spreader and the load to prevent the load hitting the spreader. Any collision could cause failure of the spreader.
- Do not undertake a lift without correct use of appropriate top slings.
- Do not hang any load from the spreader tube or flanges.
- Do not exceed stated WLL for that particular span - adhere to table 2.
- Do not rig the lower slings more than 6 degrees from vertical.
- Do not twist any slings.

